

MODEL AR-65

LF = 455KC

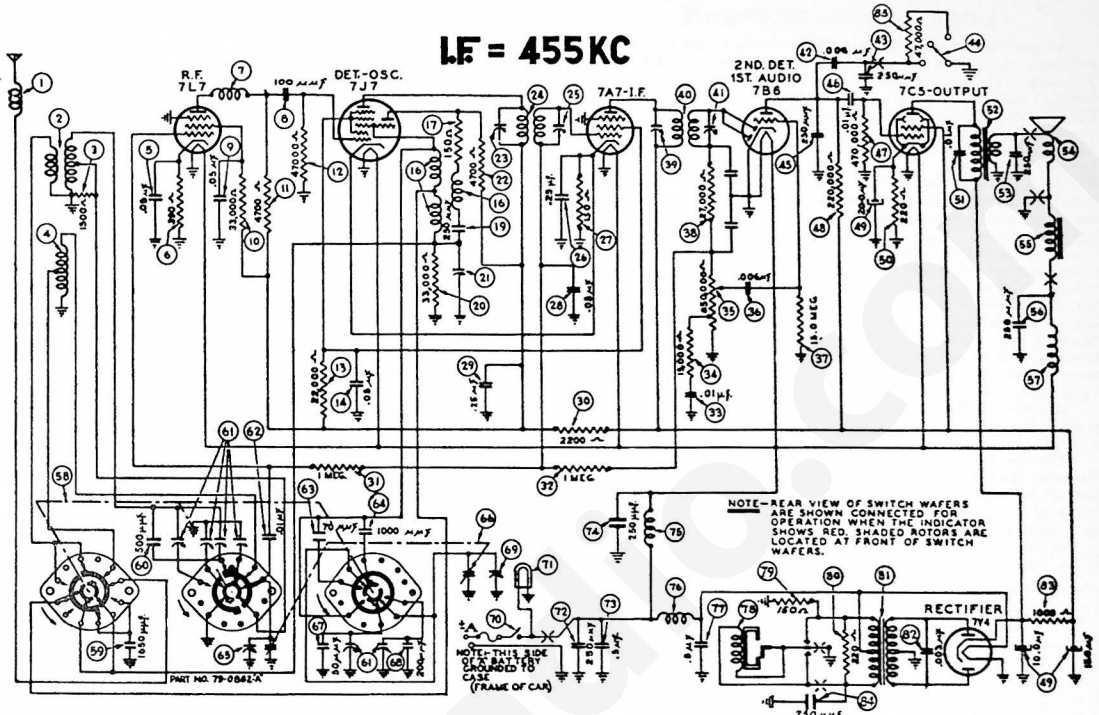

PARTS LIST — AR-65

No.	Description	Part No.	No.	Description	Part No.	No.	Description	Part No.
1	Antenna Choke	65-0340	30	Resistor (220,000 ohms)	33-422334	73	786 TUBE	
2	Short Wave Antenna		31	Filter Condenser		74	74 TUBE	RECTIFIER
3	Transformer	65-0341	32	(10-15-20 Mfd.)	61-0089	75	77 TUBE	VIBRATOR
4	Resistor (15,000 ohms)	33-215334	33	Condenser (.01 Mfd.)	61-0124	76	777 TUBE	DET. OSC.
5	Broadcast Antenna		34	Output Transformer	65-0408	77	77 TUBE	DET. OSC.
6	Transformer	65-0085	35	Condenser (250 Mmf.)	60-125157	78	77 TUBE	DET. OSC.
7	Condenser (.05 Mfd.)	61-0101	36	Replacement Cone		79	77 TUBE	DET. OSC.
8	Resistor (300 ohms)	33-139430	37	(For 73-0047-2 Speaker)	91-0086	80	77 TUBE	DET. OSC.
9	Choke	65-0347	38	(For 73-0047-3 Speaker)	91-0126	81	77 TUBE	DET. OSC.
10	Condenser (100 Mmf.)	60-110157	39	(For 73-0058-2 Speaker)	91-0086	82	77 TUBE	DET. OSC.
11	Condenser (.05 Mfd.)	61-0111	40	(For 73-0058-3 Speaker)	91-0126	83	77 TUBE	DET. OSC.
12	Resistor (33,000 ohms)	33-333334	41	Field Coil	Not Replaceable	84	77 TUBE	DET. OSC.
13	Resistor (47,000 ohms)	33-247334	42	Condenser (250 Mmf.)	60-125157	85	77 TUBE	DET. OSC.
14	Resistor (47,000 ohms)	33-347334	43	"A" Choke	77-0587	86	77 TUBE	DET. OSC.
15	Resistor (22,000 ohms)	33-322434	44	Wafer Switch	77-0587	87	77 TUBE	DET. OSC.
16	Condenser (.05 Mfd.)	61-0101	45	Mica Condenser (1650 Mmf.)	5877	88	77 TUBE	DET. OSC.
17	Oscillator Transformer	65-0339	46	Silver Mica Condenser		89	77 TUBE	DET. OSC.
18	Resistor (150 ohms)	33-115334	47	(50 Mmf.)	61-0027	90	77 TUBE	DET. OSC.
19	Condenser (.25 Mmf.)	60-125157	48	Padder Assembly	77-0580	91	77 TUBE	DET. OSC.
20	Resistor (33,000 ohms)	33-333334	49	Condenser (.01 Mfd.)	61-0110	92	77 TUBE	DET. OSC.
21	Low Frequency Padder	63-0048	50	Silver Mica Condenser		93	77 TUBE	DET. OSC.
22	Resistor (4700 ohms)	33-247344	51	(70 Mmf.)	61-0146	94	77 TUBE	DET. OSC.
23	Padder (Pri. 1st I. F. Trans.)		52	Condenser (.000 Mmf.)	61-0079	95	77 TUBE	DET. OSC.
24	First I. F. Transformer	65-0338	53	Antenna Padder (on a.m. Cond.)		96	77 TUBE	DET. OSC.
25	Padder (Sec. 1st I. F. Trans.)		54	Tuning Condenser	63-0050	97	77 TUBE	DET. OSC.
26	Condenser (.25 Mfd.)	61-0112	55	Stiver Mica Condenser		98	77 TUBE	DET. OSC.
27	Resistor (150 ohms)	33-115336	56	(50 Mmf.)	61-0140	99	77 TUBE	DET. OSC.
28	Condenser (.05 Mfd.)	61-0101	57	Silver Mica Condenser		100	77 TUBE	DET. OSC.
29	Condenser (.25 Mfd.)	61-0125	58	(200 Mmf.)	61-0141	101	77 TUBE	DET. OSC.
30	Resistor (2200 ohms)	33-222434	59	Oscillator Padder (on Tun. Cond.)		102	77 TUBE	DET. OSC.
31	Resistor		60	"On-Off" Switch	85-0112	103	77 TUBE	DET. OSC.
32	(1,000,000 ohms)	33-510154	61	Pilot Lamp	34-2039	104	77 TUBE	DET. OSC.
33	Resistor		62	Condenser (250 Mmf.)	60-125157	105	77 TUBE	DET. OSC.
34	(1,000,000 ohms)	33-510154	63	Condenser (.5 Mfd.)	61-0137	106	77 TUBE	DET. OSC.
35	Condenser (.01 Mfd.)	61-0114	64	Condenser (250 Mmf.)	60-125157	107	77 TUBE	DET. OSC.
36	Resistor (15,000 ohms)	33-315154	65	"A" Choke	32-1604	108	77 TUBE	DET. OSC.
37	Volume Control		66	Vibrator Choke	65-0075	109	77 TUBE	DET. OSC.
38	(350,000 ohms)	67-0093-2	67	Condenser (.5 Mfd.)	61-0108	110	77 TUBE	DET. OSC.
39	Condenser (.0000 Mmf.)	61-0103	68	Vibrator	83-0025	111	77 TUBE	DET. OSC.
40	Resistor		69	Resistor (150 ohms)	33-115334	112	77 TUBE	DET. OSC.
41	(15,000,000 ohms)	33-411514	70	Resistor (27,000 ohms)	33-123334	113	77 TUBE	DET. OSC.
42	Resistor (27,000 ohms)	33-331534	71	Padder (Pri. 2nd I. F. Trans.)		114	77 TUBE	DET. OSC.
43	Padder (Pri. 2nd I. F. Trans.)		72	Second I. F. Transformer	65-0320	115	77 TUBE	DET. OSC.
44	Second I. F. Transformer	65-0320	73	Padder (Sec. 2nd I. F. Trans.)		116	77 TUBE	DET. OSC.
45	Padder (Sec. 2nd I. F. Trans.)		74	Condenser (.01 Mfd.)	61-0112	117	77 TUBE	DET. OSC.
46	Condenser (.01 Mfd.)	61-0112	75	Condenser (250 Mmf.)	60-125157	118	77 TUBE	DET. OSC.
47	Condenser (.0000 Mmf.)	61-0103	76	Condenser (.5 Mfd.)	61-0137	119	77 TUBE	DET. OSC.
48	Resistor		77	Condenser (250 Mmf.)	60-125157	120	77 TUBE	DET. OSC.
49	(15,000,000 ohms)	33-411514	78	"A" Choke	32-1604	121	77 TUBE	DET. OSC.
50	Resistor (27,000 ohms)	33-331534	79	Vibrator Choke	65-0075	122	77 TUBE	DET. OSC.
51	Padder (Pri. 2nd I. F. Trans.)		80	Condenser (.5 Mfd.)	61-0108	123	77 TUBE	DET. OSC.
52	Second I. F. Transformer	65-0320	81	Vibrator	83-0025	124	77 TUBE	DET. OSC.
53	Padder (Sec. 2nd I. F. Trans.)		82	Resistor (150 ohms)	33-115334	125	77 TUBE	DET. OSC.
54	Condenser (.01 Mfd.)	61-0112	83	Resistor (27,000 ohms)	33-123334	126	77 TUBE	DET. OSC.
55	Condenser (250 Mmf.)	60-125157	84	Power Transformer	65-0318	127	77 TUBE	DET. OSC.
56	Tone Control Switch Wafer	77-0733	85	Condenser (3000 Mmf.)	61-0115	128	77 TUBE	DET. OSC.
57	Condenser (.25 Mmf.)	60-125157	86	Resistor (1000 ohms)	33-0434	129	77 TUBE	DET. OSC.
58	Condenser (.01 Mfd.)	61-0120	87	Condenser (250 Mmf.)	60-125157	130	77 TUBE	DET. OSC.
59	Resistor (470,000 ohms)	33-471154	88	Resistor (47,000 ohms)	33-343334	131	77 TUBE	DET. OSC.
60	Resistor (470,000 ohms)	33-471154	89	Receiver Housing	77-0090FC35	132	77 TUBE	DET. OSC.
61	Resistor (470,000 ohms)	33-471154	90	Speaker Socket	55-0443	133	77 TUBE	DET. OSC.
62	Resistor (470,000 ohms)	33-471154	91	Lokta Socket	55-0375	134	77 TUBE	DET. OSC.
63	Resistor (470,000 ohms)	33-471154	92	Antenna Connector	57-0591	135	77 TUBE	DET. OSC.
64	Resistor (470,000 ohms)	33-471154	93	Antenna Connector	57-0591	136	77 TUBE	DET. OSC.
65	Resistor (470,000 ohms)	33-471154	94	Antenna Connector	57-0591	137	77 TUBE	DET. OSC.
66	Resistor (470,000 ohms)	33-471154	95	Antenna Connector	57-0591	138	77 TUBE	DET. OSC.
67	Resistor (470,000 ohms)	33-471154	96	Antenna Connector	57-0591	139	77 TUBE	DET. OSC.
68	Resistor (470,000 ohms)	33-471154	97	Antenna Connector	57-0591	140	77 TUBE	DET. OSC.
69	Resistor (470,000 ohms)	33-471154	98	Antenna Connector	57-0591	141	77 TUBE	DET. OSC.
70	Resistor (470,000 ohms)	33-471154	99	Antenna Connector	57-0591	142	77 TUBE	DET. OSC.
71	Resistor (470,000 ohms)	33-471154	100	Antenna Connector	57-0591	143	77 TUBE	DET. OSC.
72	Resistor (470,000 ohms)	33-471154	101	Antenna Connector	57-0591	144	77 TUBE	DET. OSC.
73	Resistor (470,000 ohms)	33-471154	102	Antenna Connector	57-0591	145	77 TUBE	DET. OSC.
74	Resistor (470,000 ohms)	33-471154	103	Antenna Connector	57-0591	146	77 TUBE	DET. OSC.
75	Resistor (470,000 ohms)	33-471154	104	Antenna Connector	57-0591	147	77 TUBE	DET. OSC.
76	Resistor (470,000 ohms)	33-471154	105	Antenna Connector	57-0591	148	77 TUBE	DET. OSC.
77	Resistor (470,000 ohms)	33-471154	106	Antenna Connector	57-0591	149	77 TUBE	DET. OSC.
78	Resistor (470,000 ohms)	33-471154	107	Antenna Connector	57-0591	150	77 TUBE	DET. OSC.
79	Resistor (470,000 ohms)	33-471154	108	Antenna Connector	57-0591	151	77 TUBE	DET. OSC.
80	Resistor (470,000 ohms)	33-471154	109	Antenna Connector	57-0591	152	77 TUBE	DET. OSC.
81	Resistor (470,000 ohms)	33-471154	110	Antenna Connector	57-0591	153	77 TUBE	DET. OSC.
82	Resistor (470,000 ohms)	33-471154	111	Antenna Connector	57-0591	154	77 TUBE	DET. OSC.
83	Resistor (470,000 ohms)	33-471154	112	Antenna Connector	57-0591	155	77 TUBE	DET. OSC.
84	Resistor (470,000 ohms)	33-471154	113	Antenna Connector	57-0591	156	77 TUBE	DET. OSC.
85	Resistor (470,000 ohms)	33-471154	114	Antenna Connector	57-0591	157	77 TUBE	DET. OSC.
86	Resistor (470,000 ohms)	33-471154	115	Antenna Connector	57-0591	158	77 TUBE	DET. OSC.
87	Resistor (470,000 ohms)	33-471154	116	Antenna Connector	57-0591	159	77 TUBE	DET. OSC.
88	Resistor (470,000 ohms)	33-471154	117	Antenna Connector	57-0591	160	77 TUBE	DET. OSC.
89	Resistor (470,000 ohms)	33-471154	118	Antenna Connector	57-0591	161	77 TUBE	DET. OSC.
90	Resistor (470,000 ohms)	33-471154	119	Antenna Connector	57-0591	162	77 TUBE	DET. OSC.
91	Resistor (470,000 ohms)	33-471154	120	Antenna Connector	57-0591	163	77 TUBE	DET. OSC.
92	Resistor (470,000 ohms)	33-471154	121	Antenna Connector	57-0591	164	77 TUBE	DET. OSC.
93	Resistor (470,000 ohms)	33-471154	122	Antenna Connector	57-0591	165	77 TUBE	DET. OSC.
94	Resistor (470,000 ohms)	33-471154	123	Antenna Connector	57-0591	166	77 TUBE	DET. OSC.
95	Resistor (470,000 ohms)	33-471154	124	Antenna Connector	57-0591	167	77 TUBE	DET. OSC.
96	Resistor (470,000 ohms)	33-471154	125	Antenna Connector	57-0591	168	77 TUBE	DET. OSC.
97	Resistor (470,000 ohms)	33-471154	126	Antenna Connector	57-0591	169	77 TUBE	DET. OSC.
98	Resistor (470,000 ohms)	33-471154	127	Antenna Connector	57-0591	170	77 TUBE	DET. OSC.
99	Resistor (470,000 ohms)	33-471154	128	Antenna Connector	57-0591	171	77 TUBE	DET. OSC.
100	Resistor (470,000 ohms)	33-471154	129	Antenna Connector	57-0591	172	77 TUBE	DET. OSC.
101	Resistor (470,000 ohms)	33-471154	130	Antenna Connector	57-0591	173	77 TUBE	DET. OSC.
102	Resistor (470,000 ohms)	33-471154	131	Antenna Connector	57-0591	174	77 TUBE	DET. OSC.
103	Resistor (470,000 ohms)	33-471154	132	Antenna Connector	57-0591	175	77 TUBE	DET. OSC.
104	Resistor (470,000 ohms)	33-471154	133	Antenna Connector	57-0591	176	77 TUBE	DET. OSC.
105	Resistor (470,000 ohms)	33-471154	134	Antenna Connector	57-0591	177	77 TUBE	DET. OSC.
106	Resistor (470,000 ohms)	33-471154	135	Antenna Connector	57-0591	178	77 TUBE	DET. OSC.
107	Resistor (470,000 ohms)	33-471154	136	Antenna Connector	57-0591	179	77 TUBE	DET. OSC.
108	Resistor (470,000 ohms)	33-471154	137	Antenna Connector	57-0591	180	77 TUBE	DET. OSC.
109	Resistor (470,000 ohms)	33-471154	138	Antenna Connector	57-0591	181	77 TUBE	DET. OSC.
110	Resistor (470,000 ohms)	33-471154	139	Antenna Connector	57-0591	182	77 TUBE	DET. OSC.
111	Resistor (470,000 ohms)	33-471154	140	Antenna Connector	57-0591	183	77 TUBE	DET. OSC.
112	Resistor (470,000 ohms)	33-471154	141	Antenna Connector	57-0591	184	77 TUBE	DET. OSC.
113	Resistor (470,000 ohms)	33-471154	142	Antenna Connector	57-0591	185	77 TUBE	DET. OSC.
114	Resistor (470,000 ohms)	33-471154	143	Antenna Connector	57-0591	186	77 TUBE	DET. OSC.
115	Resistor (470,000 ohms)	33-471154	144	Antenna Connector	57-0			

